

REV.	DESCRIPTION	DATE	BY

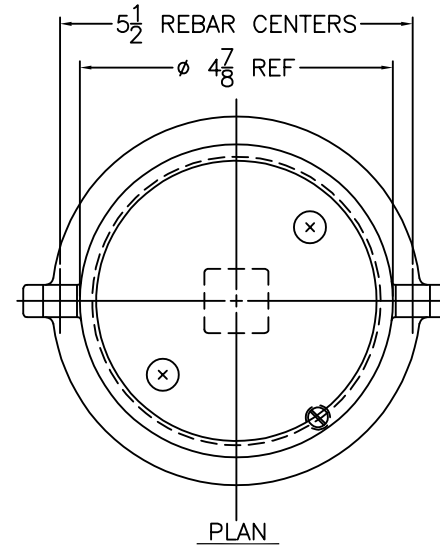
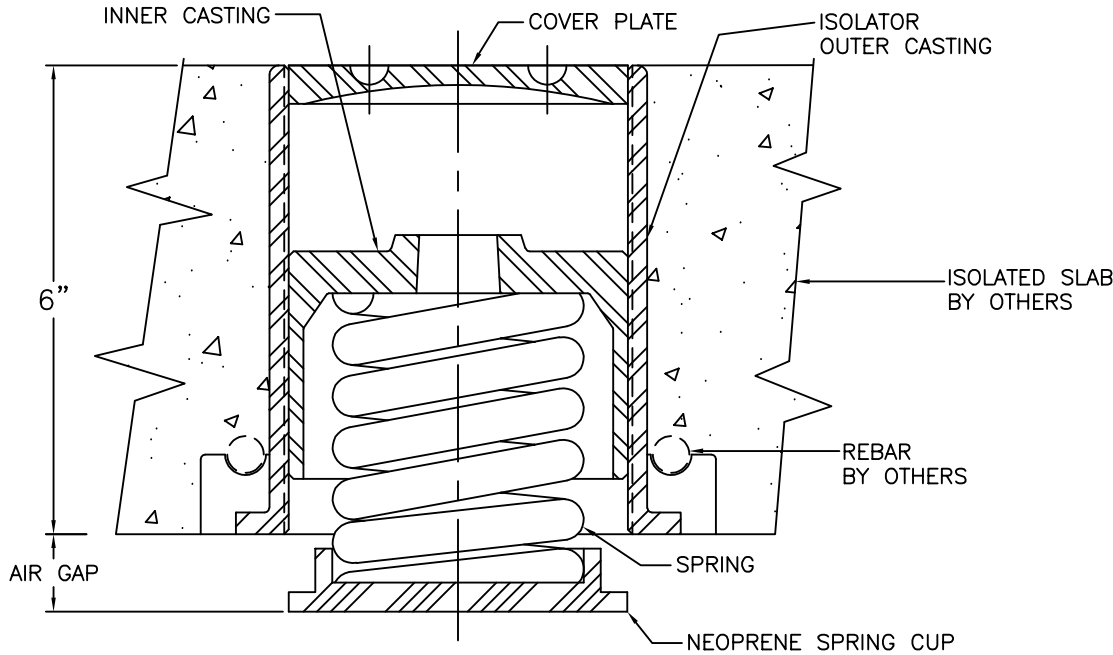

1E SERIES  
 COMPLETED ASSEMBLY SHOWN WITH LOAD APPLIED  
 AND LIFT POSITION

NOTE:  
 1. TWO NESTED SPRINGS YIELD THIS LOAD. THE COLOR CODE INDICATED IS FOR OUTER SPRING/ INNER SPRING.

ESTIMATED UNIT WEIGHT: 14.6 LBS

MODEL DESIGNATION	MAX LOAD (LBS)	DEFLECTION (IN)	COLOR CODE
ASFF-6-1E-195	195	1.95	DK. BLUE
ASFF-6-1E-400	400	1.32	BLACK
ASFF-6-1E-530N <sup>1</sup>	530	1.17	BLACK/DK. BLUE
ASFF-6-1E-650	650	1.05	RED
ASFF-6-1E-825N <sup>1</sup>	825	1.07	RED/DK. BLUE
ASFF-6-1E-1000	1000	1.00	TAN
ASFF-6-1E-1200N <sup>1</sup>	1200	1.04	TAN/DK. BLUE
ASFF-6-1E-1400	1400	1.00	PINK
ASFF-6-1E-1700N <sup>1</sup>	1700	1.10	PINK/DK. BLUE
ASFF-6-1E-2000	2000	1.11	WHITE
ASFF-6-1E-2575N <sup>1</sup>	2575	1.11	WHITE/ DK. PURPLE
ASFF-6-1E-2990N <sup>1</sup>	2990	1.11	WHITE/ DK. GREEN

OTHER MATERIALS, COMPOUNDS, OR FINISHES WITH EQUAL OR SUPERIOR PROPERTIES MAY BE SUBSTITUTED AS THEY BECOME AVAILABLE.

**CERTIFIED FOR:**

JOB NAME: \_\_\_\_\_  
 CUSTOMER : \_\_\_\_\_  
 CUSTOMER P.O.: \_\_\_\_\_  
 SALES ORDER: \_\_\_\_\_

MODEL ASFF-6-1E 195-2990 LBS.  
 SPRING ISOLATOR  
 6 INCH FLOATING FLOOR  
 1 INCH DEFLECTION



**VMC GROUP**  
 THE POWER OF TOGETHER™  
 Bloomingdale, NJ 07403  
 Houston, TX 77041

SCALE:

NONE

SHEET:



DRAWING NO.:

REVISION

REV.	DESCRIPTION	DATE	BY

**INSTALLATION MATERIALS:**

1. POLYETHYLENE PLASTIC SHEETING, 6 MIL THICK
2. FLOATING FLOOR SPRING MOUNTS AS REQUIRED
3. PERIMETER ISOLATION BOARD: 3/4" THICK, 10 LB DENSITY FIBERGLASS OR 1/2" THICK NEOPRENE SPONGE RUBBER.
4. CAULKING COMPOUND: NON-HARDENING, NON-DRYING.
5. FLOATING FLOOR DRAINS AS REQUIRED.
6. RISER SEALS AS REQUIRED.

**FLOOR SYSTEM ADJUSTMENT PROCEDURE:**

1. STRUCTURAL FLOOR MUST BE LEVEL AT MOUNT LOCATIONS, AS MOUNTS ARE USED AS SCREED POINTS SMOOTHNESS AT MOUNT LOCATIONS TO BE ±0.03"
2. SET CONCRETE PERIMETER FORMS AS REQUIRED.
3. CEMENT PERIMETER ISOLATION BOARDS TO WALLS, FORMS, AROUND COLUMNS, ETC. AS REQUIRED.
4. SNAP CHALK LINES TO LOCATE MOUNTS ON THE SUB-FLOOR. INDICATE MOUNT LOCATIONS SO THAT THEY ARE VISIBLE THROUGH THE POLYETHYLENE SHEETING.
5. LAY SHEETING OVER THE ENTIRE FLOOR AREA. LAP UP AND OVER THE PERIMETER BOARDS AND TAPE IN POSITION. OVERLAP AT LEAST 12" AT SEAMS. TAPE SEAL ALL SEAMS.
6. INSPECT ALL MOUNTS PRIOR TO PLACEMENT, INSURING THAT ALL THREADS ARE GREASED. ENSURE THAT THE NEOPRENE SPRING CUP, AND CASTING COMPRESSION PLATE ARE INSTALLED AS SHOWN ON SHEET 1 OR 2, AS APPROPRIATE. CAULK SPANNER HOLES.
7. PLACE CASTINGS IN ACCORDANCE WITH THE LAYOUT DRAWINGS. IN NO INSTANCE, SHOULD THE SPACING BE MORE THAN 48" ON CENTER, UNLESS SPECIFICALLY APPROVED BY THE ENGINEER OF RECORD.
8. INSTALL REINFORCING AS PER THE CONTRACT DRAWINGS, AND APPROVED STANDARD PRACTICE.
9. POUR CONCRETE TO THE REQUIRED THICKNESS AND FINISH FLUSH WITH THE TOPS OF THE FLOATING FLOOR MOUNTS. POUR CONCRETE IN ONE CONTINUOUS POUR. INSURE NO VOIDS AROUND THE REINFORCING AND THE MOUNTS. CAUTION: DO NOT SHIFT OR LIFT THE MOUNTS.

10. AFTER CONCRETE HAS CURED FULLY AND THE FLOOR IS READY FOR LIFTING, EACH MOUNT MUST BE PREPARED FOR SPRING INSTALLATION AS FOLLOWS:
  - A. REMOVE CAULKING FROM SPANNER HOLES.
  - B. UNSCREW AND REMOVE COVER PLATE. NOTE: DO NOT MIX COVER PLATES. EACH COVER PLATE IS MATCH DRILLED TO ITS CORRESPONDING MOUNT.
  - C. REMOVE CASTING COMPRESSION PLATE AND SET ASIDE. NOTE: DO NOT MIX CASTING COMPRESSION PLATES. PLATE IS MATCH DRILLED TO ITS CORRESPONDING MOUNT.
  - D. INSTALL THE NEOPRENE SPRING CUP AND THE APPROPRIATE SPRING(S) AT EACH LOCATION.
  - E. REINSTALL THE CASTING COMPRESSION PLATE UNTIL IT JUST BEARS ON THE SPRING(S). REFERENCE FIGURE 2.
11. USING A 1" SQUARE "T" WRENCH, TAKE TWO (2) FULL CONSECUTIVE, CLOCKWISE TURNS ON EVERY CASTING COMPRESSION PLATE. WORK CAN PROCEED EITHER AT ONE LOCATION OR A GROUP OF LOCATIONS AT A TIME.
12. REPEAT STEP 11 UNTIL THE FLOOR IS RAISED TO THE REQUIRED ELEVATION. APPROXIMATELY EIGHT (8) TURNS OF THE CASTING COMPRESSION PLATE IS REQUIRED IN ORDER TO COMPRESS THE SPRING ONE (1) INCH. SUBSEQUENT TURNS AFTER THE SPRINGS ARE COMPRESSED RESULT IN RAISING THE FLOOR.
13. LEVEL THE FLOOR AS NECESSARY, BY MAKING ADDITIONAL CLOCKWISE TURNS ON ALL OF THE MOUNTS ON THE LOW END OF THE FLOOR.
14. INSTALL THE COVER PLATES IN THEIR RESPECTIVE LOCATIONS, FLUSH WITH THE TOP OF THE FLOOR.
15. ONE COMPONENT USED ON RESPECTIVE MOUNT AND SPRING COMBINATION. SEE MOUNT TYPE ILLUSTRATION ON SHEET 1 AND 2.

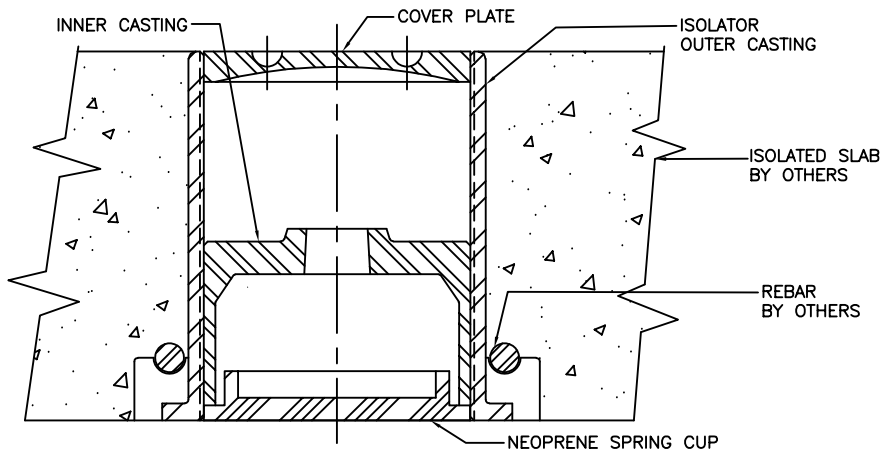

1E SERIES  
SHOWN IN POURING POSITION

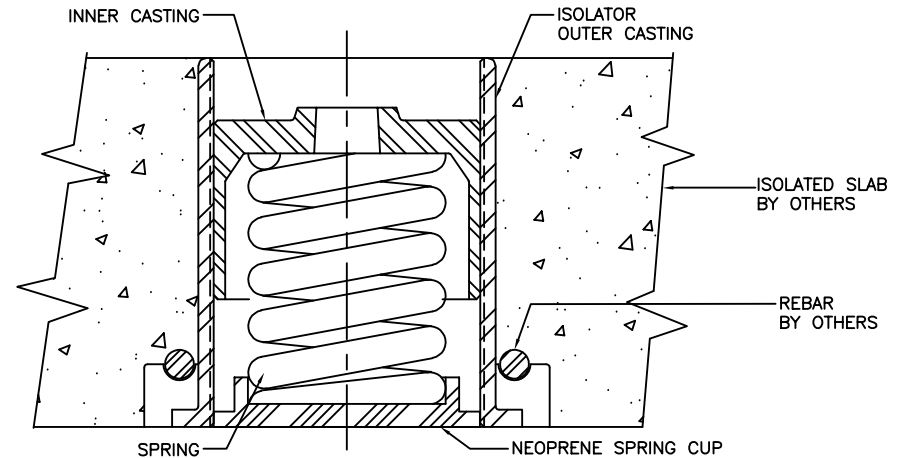

1E SERIES  
SHOWN AS READY TO LIFT  
© FREE HEIGHT, NO LIFT POSITION

OTHER MATERIALS, COMPOUNDS, OR FINISHES WITH EQUAL OR SUPERIOR PROPERTIES MAY BE SUBSTITUTED AS THEY BECOME AVAILABLE.

**CERTIFIED FOR:**

JOB NAME: \_\_\_\_\_  
 CUSTOMER : \_\_\_\_\_  
 CUSTOMER P.O.: \_\_\_\_\_  
 SALES ORDER: \_\_\_\_\_

MODEL ASFF-6-1E 195-2990 LBS.  
 SPRING ISOLATOR  
 6 INCH FLOATING FLOOR  
 1 INCH DEFLECTION



**VMC GROUP**  
 THE POWER OF TOGETHER™  
 Bloomingdale, NJ 07403  
 Houston, TX 77041

SCALE: NONE	
SHEET:	
DRAWING NO.:	REVISION: